

30 year dimensional shingles and Metal Verticle siding over structural sheathing. Nailing schedule is 6" on ends 12" on centers 6d nails. Trusses are engineered on 24" and framing is 2" x 4" on 16" centers. 10" ceiling height.



To the best of my knowledge these plans are drawn to comply with owner's and/ or builder's specifications and any changes made on them after prints are made will be done at the owner's and / or builder's expence and responsibility. The contractor shall verify all dimensions and enclosed drawing. SDSCAD is not liable for errors once construction has begun. While every effort has been made in the preparation of this plan to avoid mistakes, the maker can not guarantee against human error. The contractor of the job must check all dimensions and other details prior to construction and be solely responsible thereafter. All calculations and member sizing should be verified for your building by a certified building official.

BUILDING CONTRACTOR/HOME OWNER TO REVIEW AND VERIFY ALL DIMENSIONS, SPECS, AND CONNECTIONS BEFORE CONSTRUCTION BEGINS. GARAGE TO BE BUILT AS PER IRC 2006 OR CURRENT LOCAL CODE

36 x 36 - 10' Sides Garage Plan Plan #g313

By SDS-CAD Specialized Design Systems

Page 1	Title Main Floor Plan
Page 2	Elevation Views
Page 3	Foundation Plan & Pictorials
Page 4	Framing and Details
Page 5	Detail Page
Page 6	Materials List

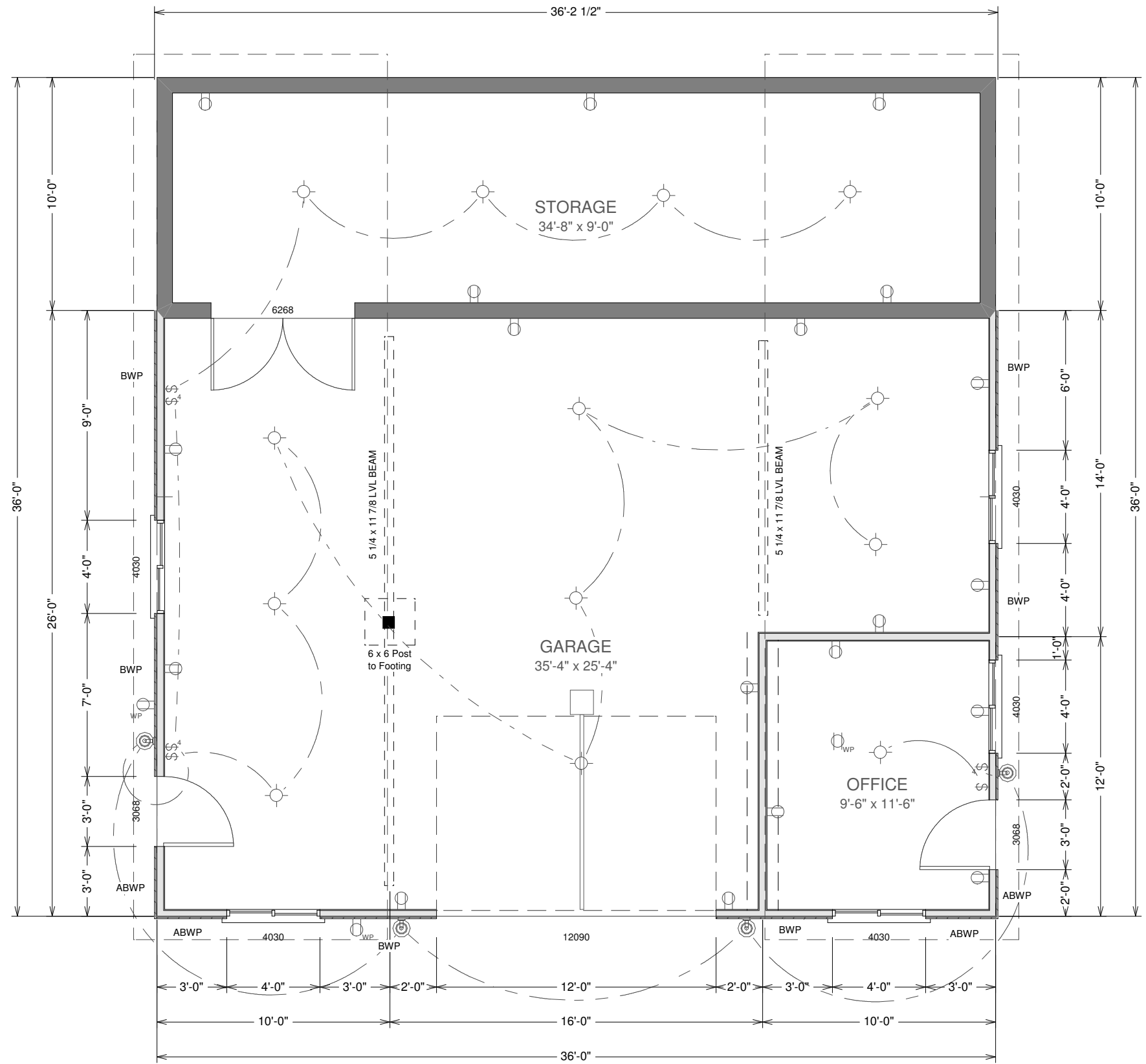

GARAGE MAIN FLOOR PLAN

SCALE
3/16"=1'

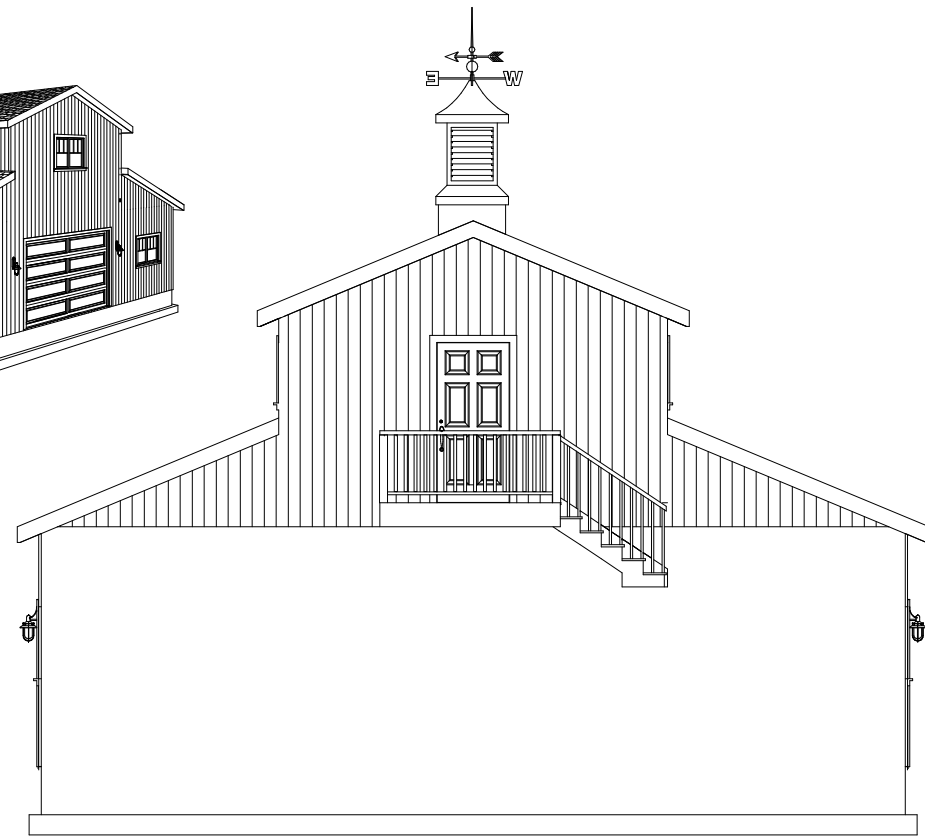
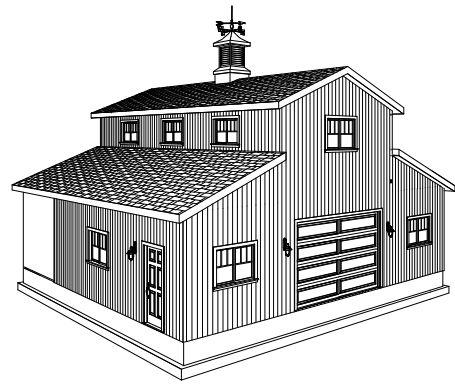

REAR ELEVATION

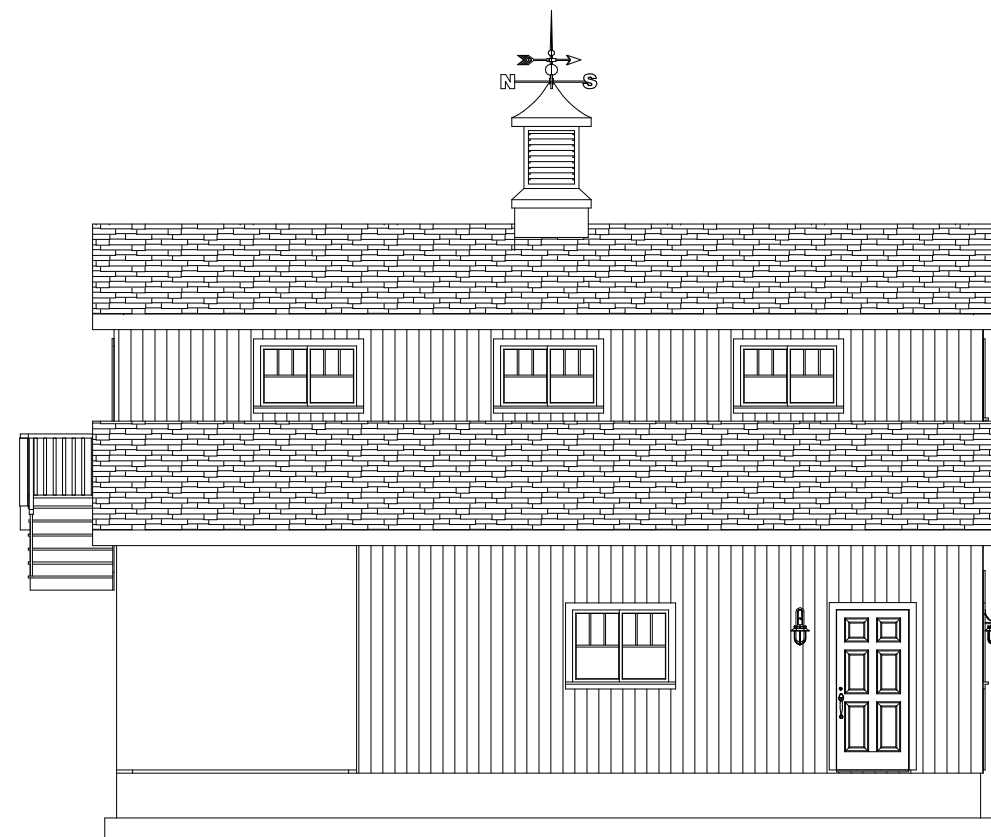

LEFT ELEVATION

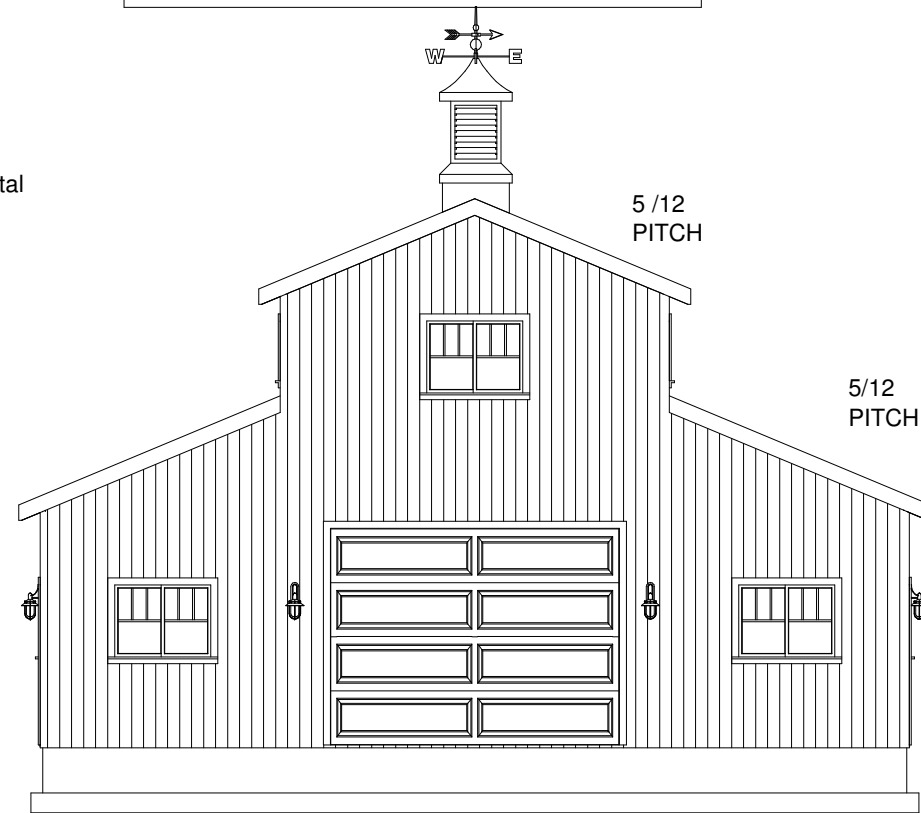

FRONT ELEVATION

10' Tall 2 x 4 Walls
Asphalt Shingles

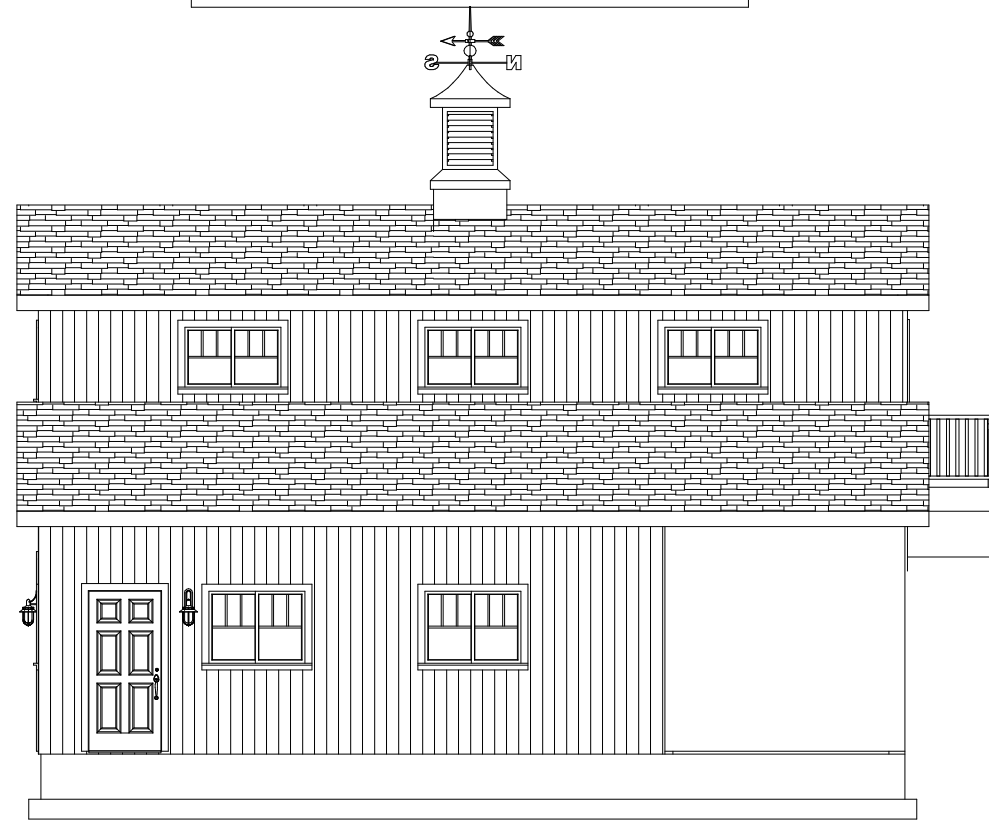

RIGHT ELEVATION

Vertical Metal
Siding

5 /12
PITCH

5/12
PITCH

SCALE
1/8"=1'

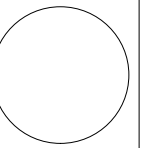

CLIENT	
DATE	
DRAWN BY	
CHECKED BY	
DATE	
REVISIONS	
JOB NO.	

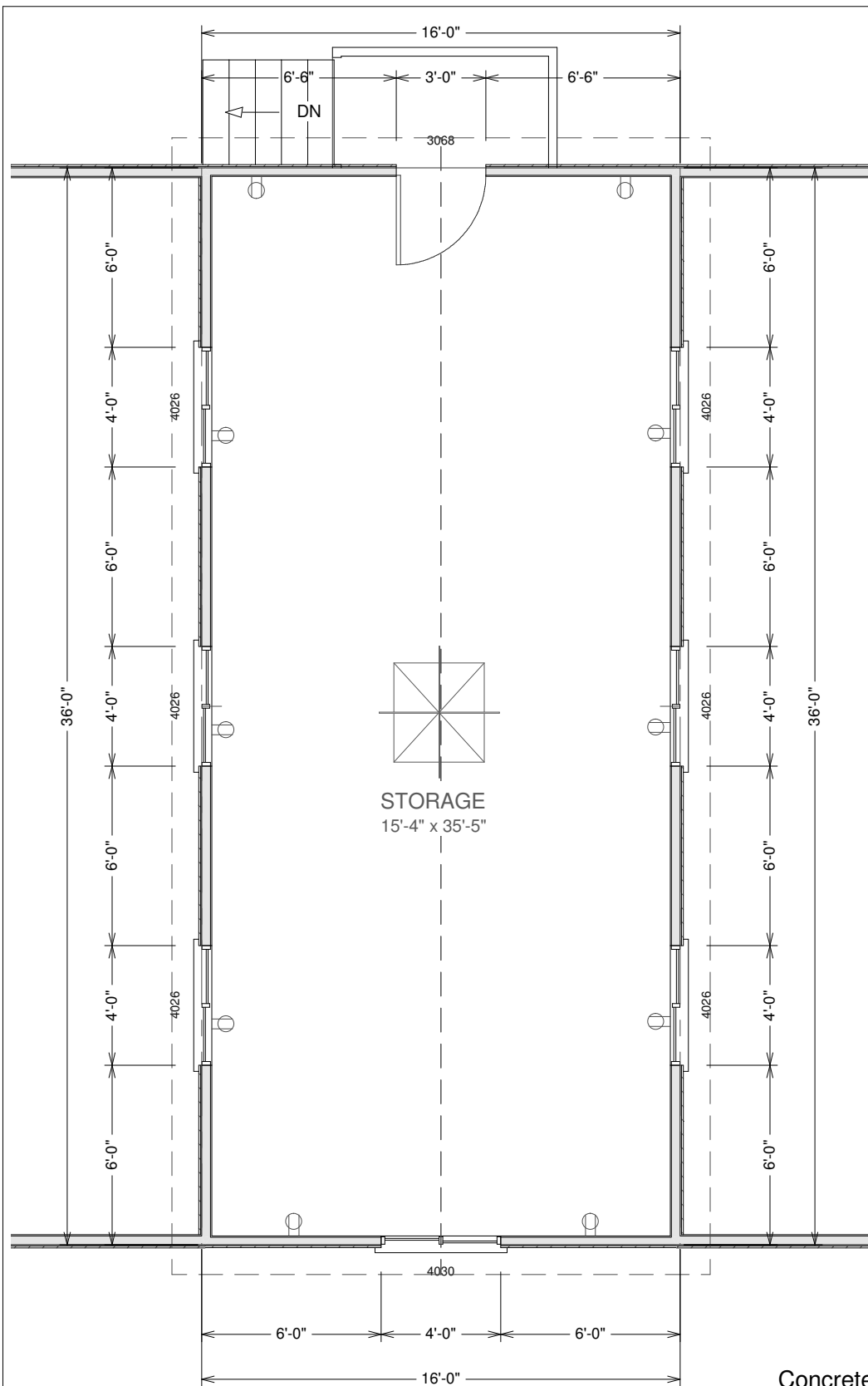

2ND FLOOR PLAN

SCALE
3/16"=1'

Concrete:

1. All slabs are to be 4" concrete over 4" gravel unless otherwise noted on the plans.
2. Concrete to be ACI 301-66, Type II cement, 2500 psi at 28 days, 5" maximum slump.
3. Reinforcing to be ASTM A615-Bars with $F_y=60$ ksi lap 30 diameter minimum at splices or weld per ACI Std.
4. Concrete design based on F_c 2000 psf, F_c 2500 psi for quality only.
5. Anchor bolts shall be A-307 embedded 7" minimum into concrete or masonry grout.
6. All footings minimum 24" below final grade

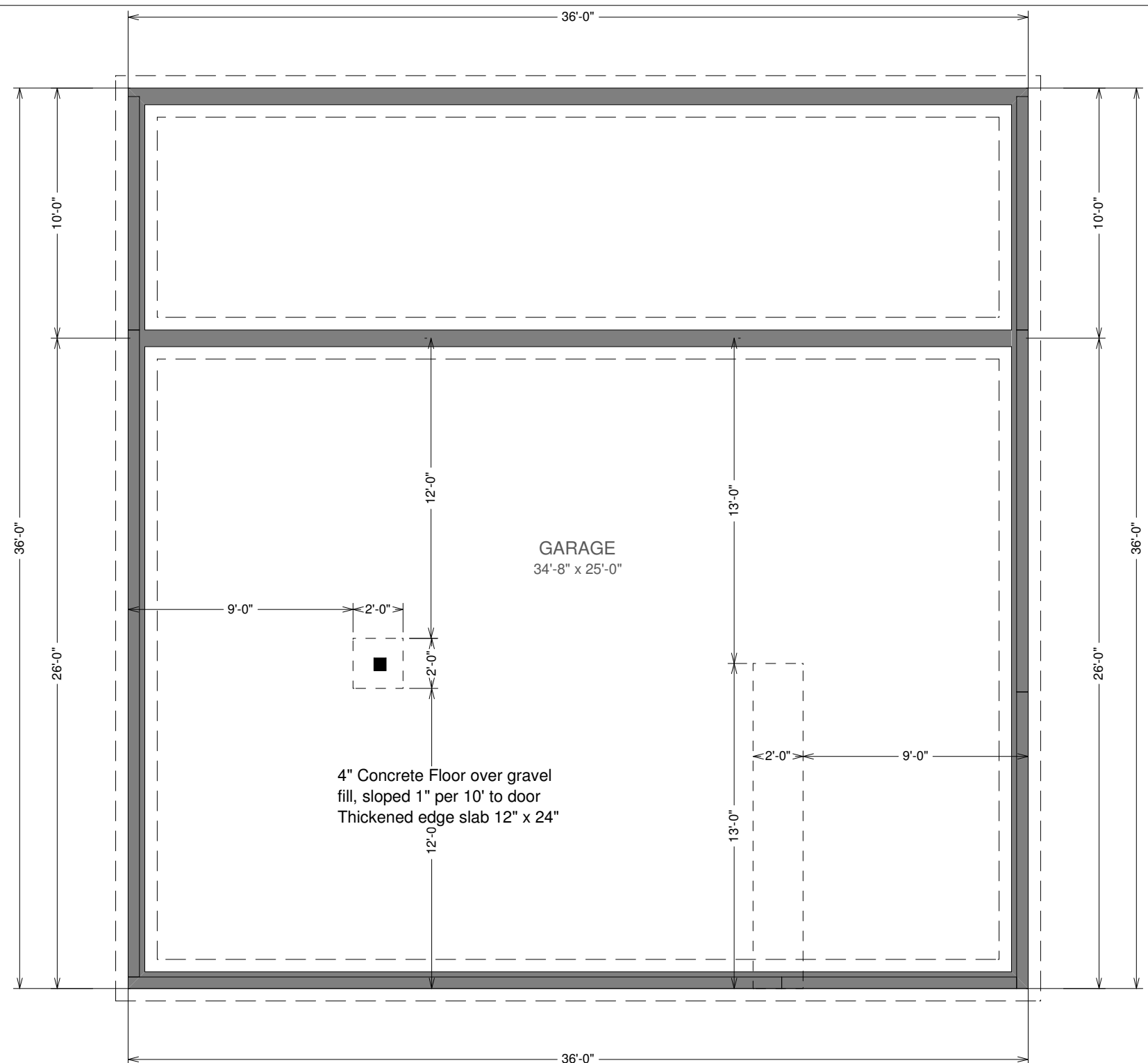

FOUNDATION PLAN

SCALE 3/16"=1'

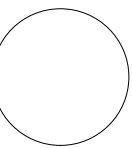
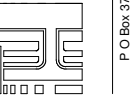

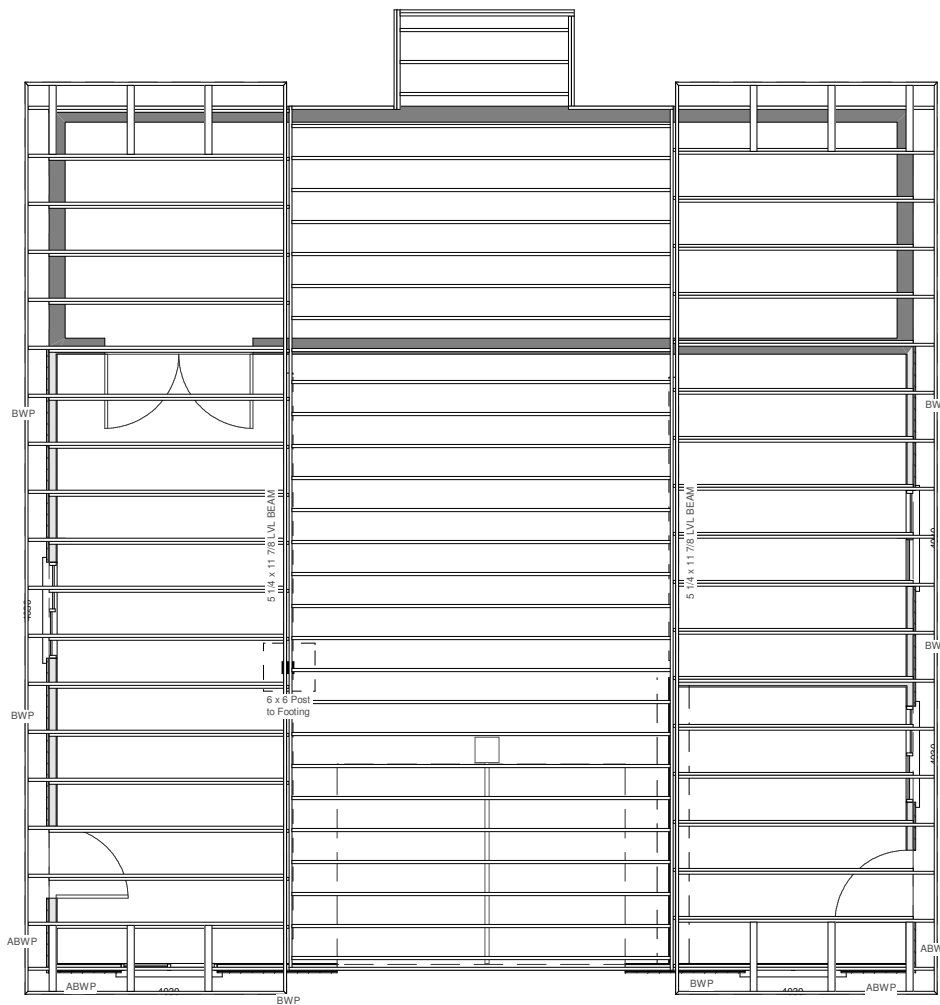

10' Tall 2 x 4 Walls
GARAGE ROOF PRE-ENGINEERED TRUSSES AS SUPPLIED BY
TRUSS MANUFACTURER 24" o.c.

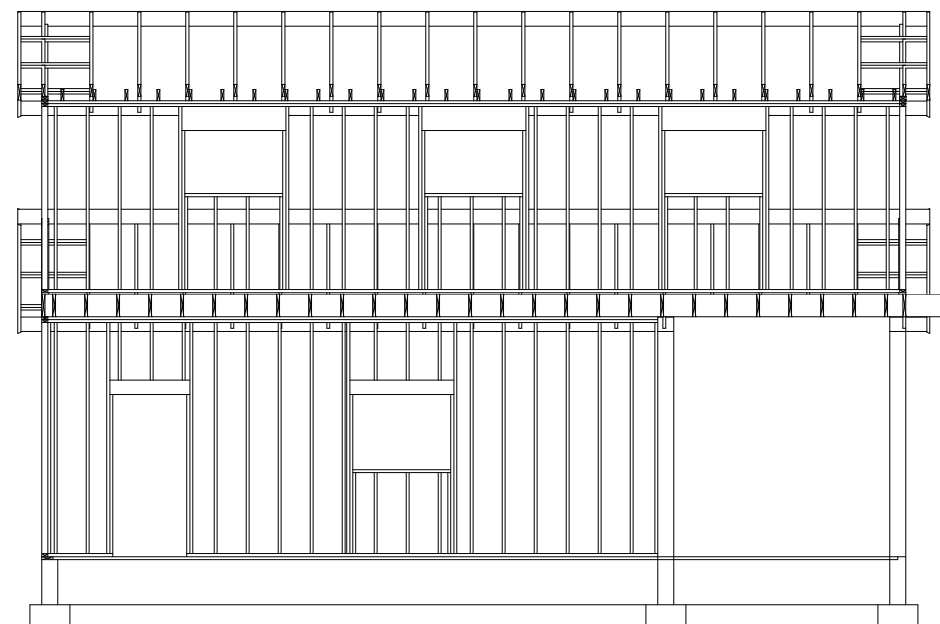

Cross Section

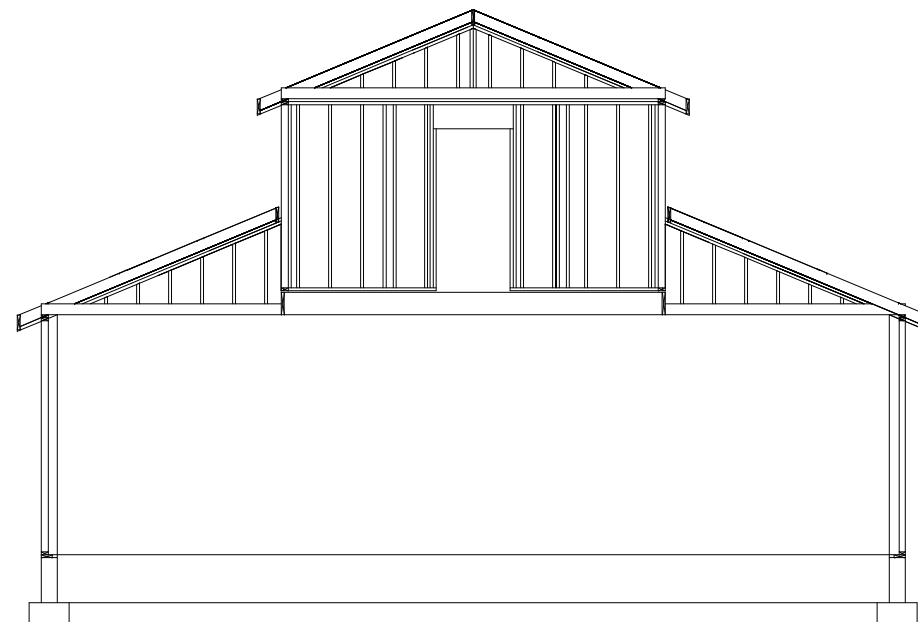
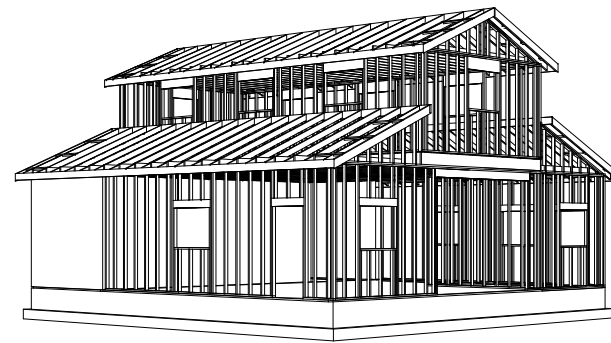

Back Wall

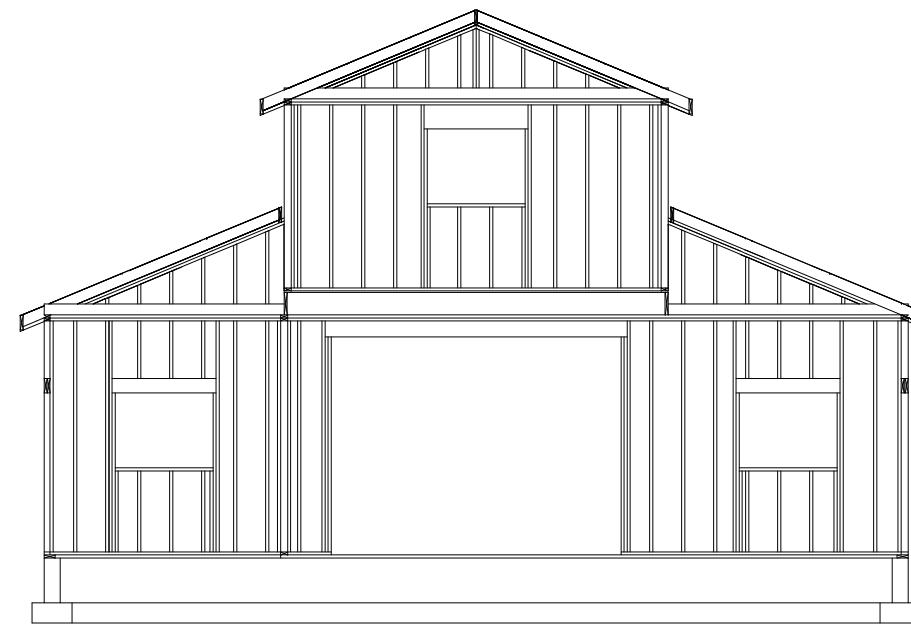

Front Wall

WALL FRAMING SECTIONS

SCALE 1/8"=1'

General framing: (Douglas Fir)

- Minimum header sizes shall be according to the following table unless otherwise noted. Header sizes (single story construction)
 2'-0" to 4'-0" Span 2-2x4's
 4' + to 6'-0" Span 2-2x6's
 6' + to 8'-0" Span 2-2x8's
 8' + to 10'-0" Span 2-2x10's
 10' + to 12'-0" Span 2-2x12's or as noted on plan
- Brace all exterior walls and cross-stud partitions at each end of building and at least every 25' of length by one of the following:
 a. Simpson WB 126 wall bracing with 3-16d nails at each end and 1-8d nails at each stud.
 b. Plywood sheathing of a minimum thickness of 7/16 inch.
- Fire stopping:
 a. Fireblock stud spaces over 10' in height, furred spaces, soffits, drop ceilings, cove ceilings, stair stringers at top and bottom of run, bearing walls and ceiling joist lines, etc. Firestopping shall consist of 2" nominal lumber.
 b. Firestop openings around vents, pipes, ducts, chimneys, and fireplaces at ceiling and floor levels with approved noncombustible materials.
- CDX plywood is not approved where exposed to weather, i.e., roof overhangs.
- Exterior wall framing to be 2"x6" studs at 16" o.c. Interior wall, framing at non-bearing walls to be 2"x4" studs at 24" o.c. and at bearing walls 2"x4" studs at 16" o.c. with double top plate.
- Shear wall to be 7/16" Sheathing, see detail.
- All stress grade lumber shall comply with WCLA specs and bear approval stamp on all pieces in place.
- Framing lumber shall be Douglas Fir construction grade Fb 1450 or better unless otherwise noted.
- Nailing to be per current U.B.C. unless otherwise noted.
- All bearing partitions shall have double top plates.
- Structural glued laminated timbers to be stamped by an approved agency.
- Use redwood or pressure treated sole plates at all exterior walls.

Roof Framing:

- Fascia to be 2"x Douglas Fir.
- For soffit size see details.
- For spans and dimensions refer to floor plans.
- Trusses are to be an approved truss design from the truss manufacture's engineer.
- Use Simpson H-1 hurricane anchors at each truss or rafter to wall connection.
- Solid blocking required between joists, rafters, and trusses over all bearing walls. Such blocking shall be 1 1/2" minimum thickness and full depth of joists, rafters, or trusses.
- Minimum header sizes shall be according to the header size table unless otherwise noted.
- Basis of design roof live/snow load of 37 psf, and roof dead load of 15 psf.
- Plywood roof decking to be Min 1/2" thick, 24/0, CDX or 5/8 wafer.

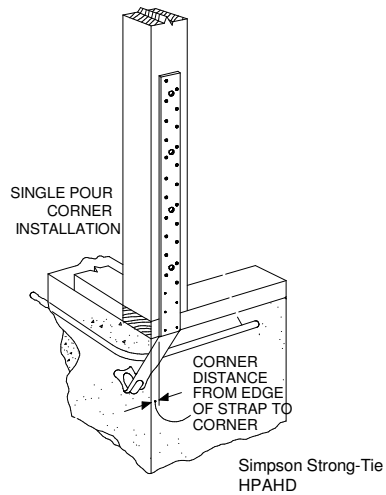

HPAHD straps for all (ABWP) Alternate Braced Wall Panels
See additional detail for all (BWP) Braced Wall Panels

TYPICAL ALTERNATE BRACED WALL PANEL (ABWP)

NOTE: TYPICAL DETAILS FOR BASIC CONSTRUCTION PURPOSES AND BUILDING REQUIREMENTS. GARAGES TO BE BUILT AS PER LOCAL CODE REQUIREMENTS

CDX PLYWOOD SHEAR WALL INSTALLED W/ LONG DIMENSION ACROSS STUDS. STAGGER VERTICAL JOINTS

PANEL SHEATHING USED AS CORNER BRACING W/ LONG DIMENSION PARALLEL TO STUDS

LEAVE 1/4" GAP @ EDGES & 1/8" GAP @ ENDS UNLESS OTHERWISE RECOMMENDED BY MANUFACTURER

WALL FRAMING

SIDING MATERIAL STRUCTURAL PANEL CAN ACT AS SIDING IF OF EXTERIOR GRADE

10d NAILS @ 6" O.C. AT EDGES & SEAMS AND 10d NAILS @ 12" O.C. IN FIELD U.N.O. ON SHEAR WALL SCHEDULE

TYPICAL BRACED WALL PANEL (BWP)

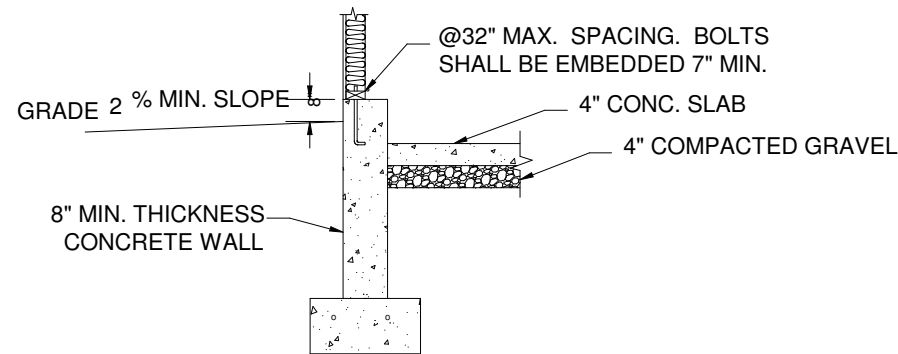

Footing and concrete wall option

Bottom of footing to be a min of 30" below grade or as required by local code

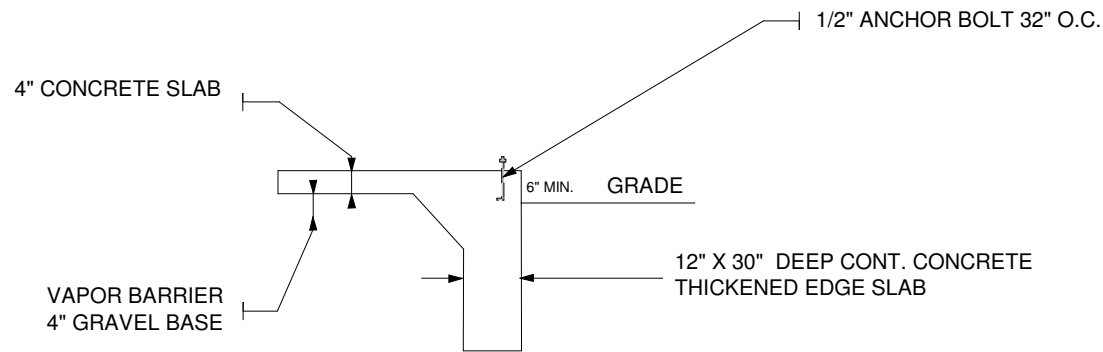

Monolithic slab foundation option

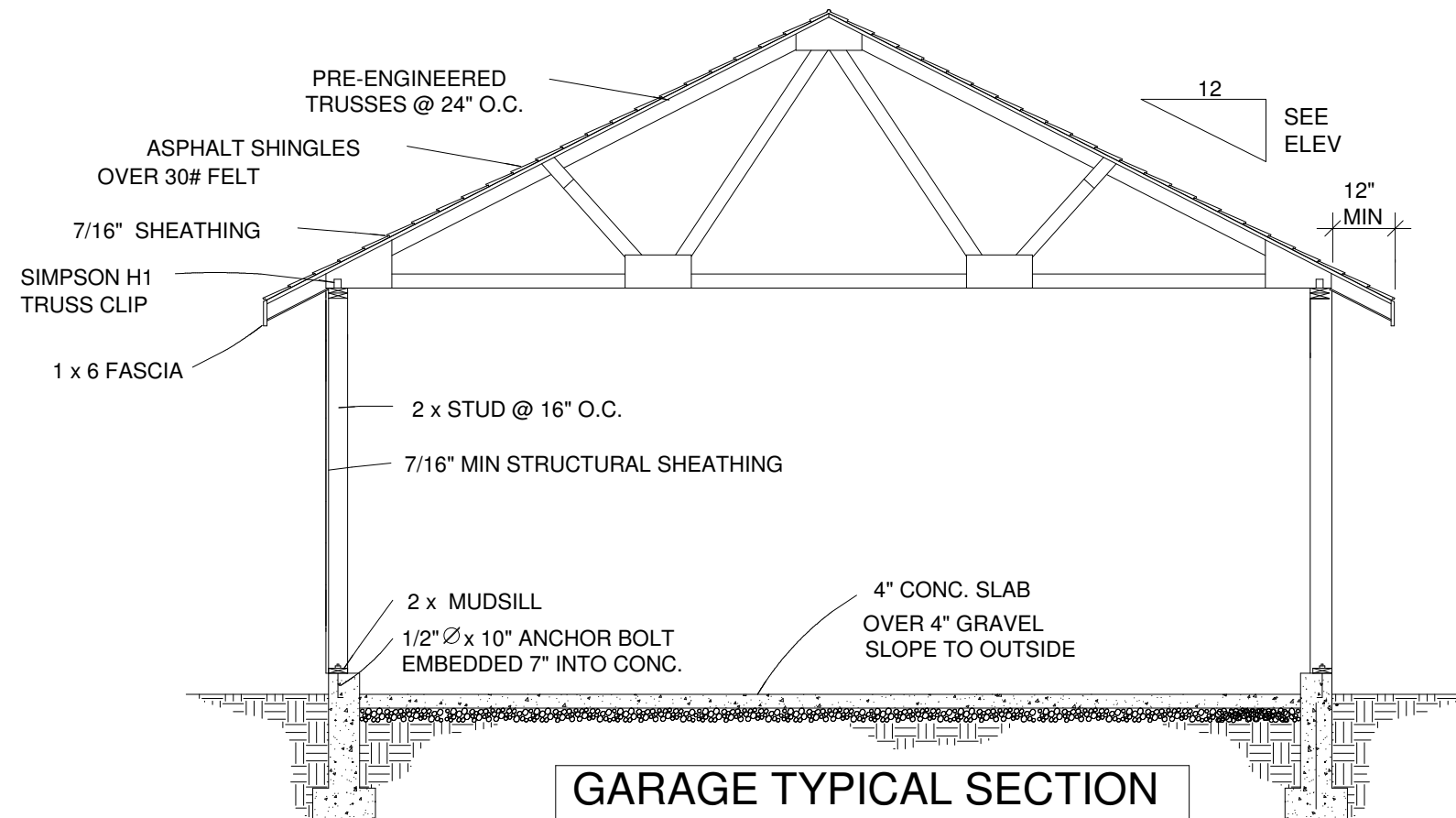

GARAGE TYPICAL SECTION

